



TISC



Interreg



EURÓPSKA ÚNIA

Slovenská republika-Maďarsko

Partnerséget építünk

IPARI

1872

2022

150

Akkor...
...és most



Gépészeti felsőbb ipartanoda

1872

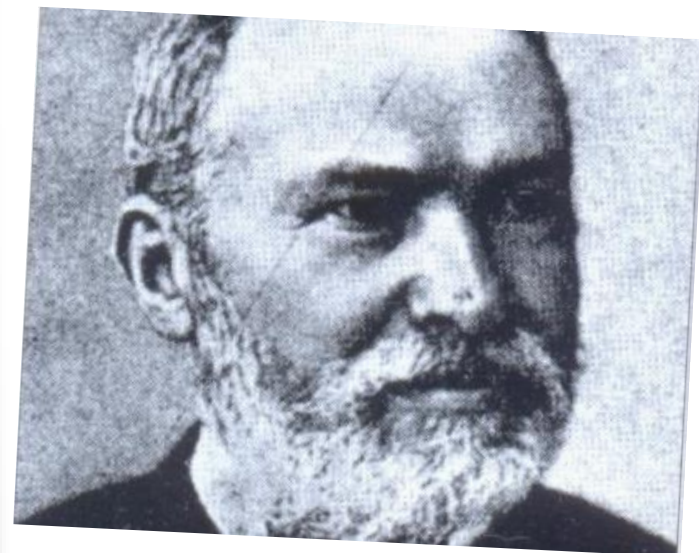
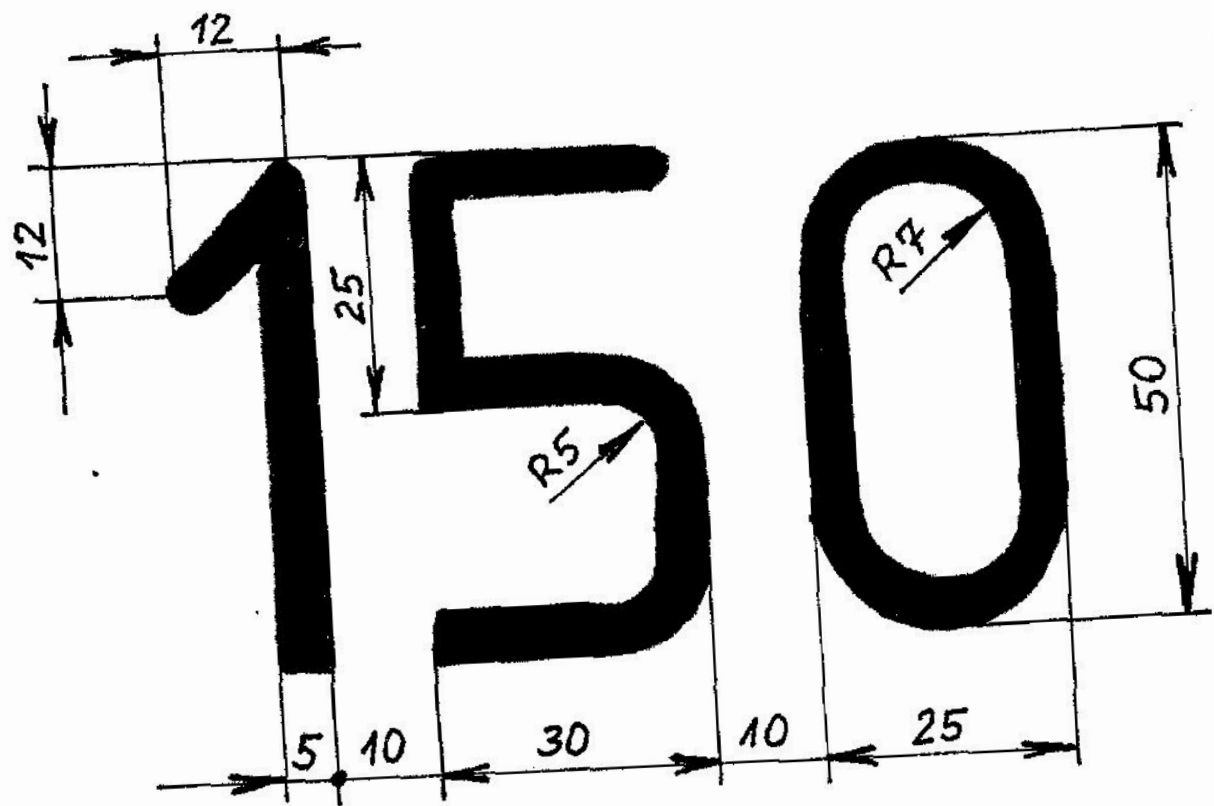

Galley Porsey
igazgató-tanár

mi voltunk előbb...

1872

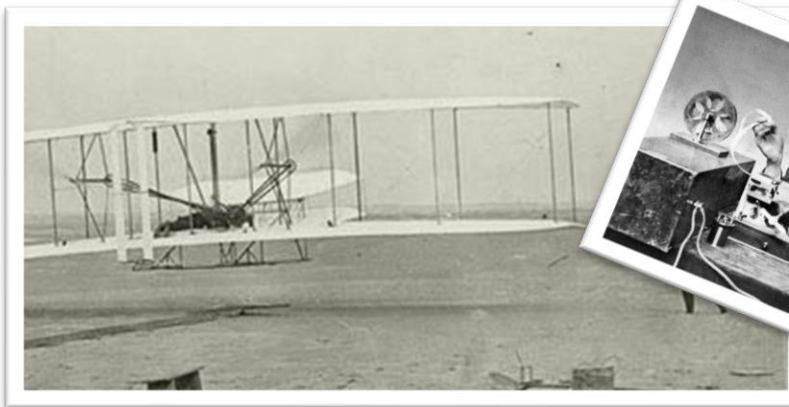
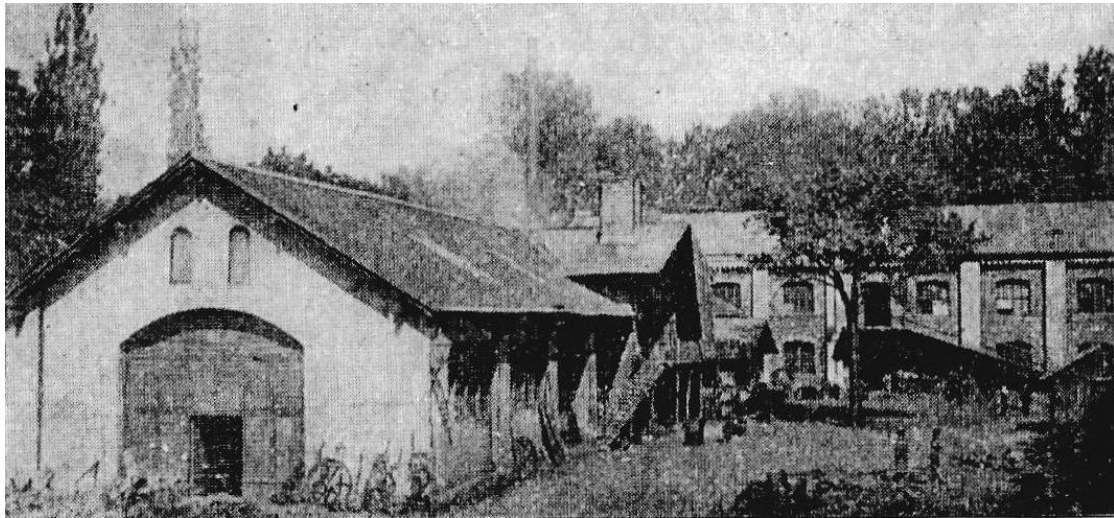

... aztán a világ...

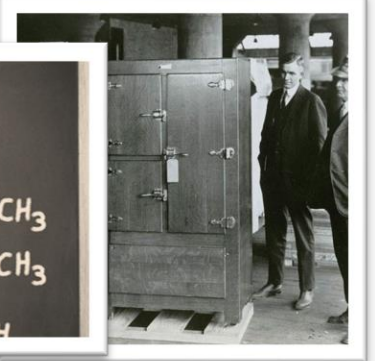
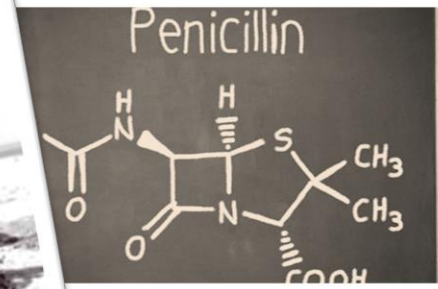

Igazgatók



Szakkay József



Tetmajer Károly

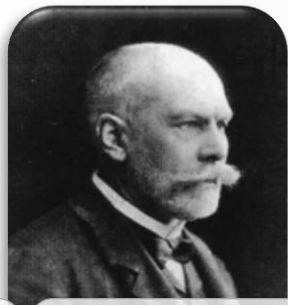

Hinsenkamp Bernát



Dömötör Pál



Balassa János



Václav Mayer



Maximilian Klotz



Antonín Benda



Juraj Krajčovič



Koch Vilmos



Körtvélyessi Dezső



Schmidt József



Bajúz Ferenc



Cservenka József



Csudáky Andor



Schulz György



Boda Pál



Nógell Tibor



Albert Sándor



Nyárfás Károly



Bárány János



Pulen Lajos



Matej Éva

TANÁRI KAR



Végzett iparisták

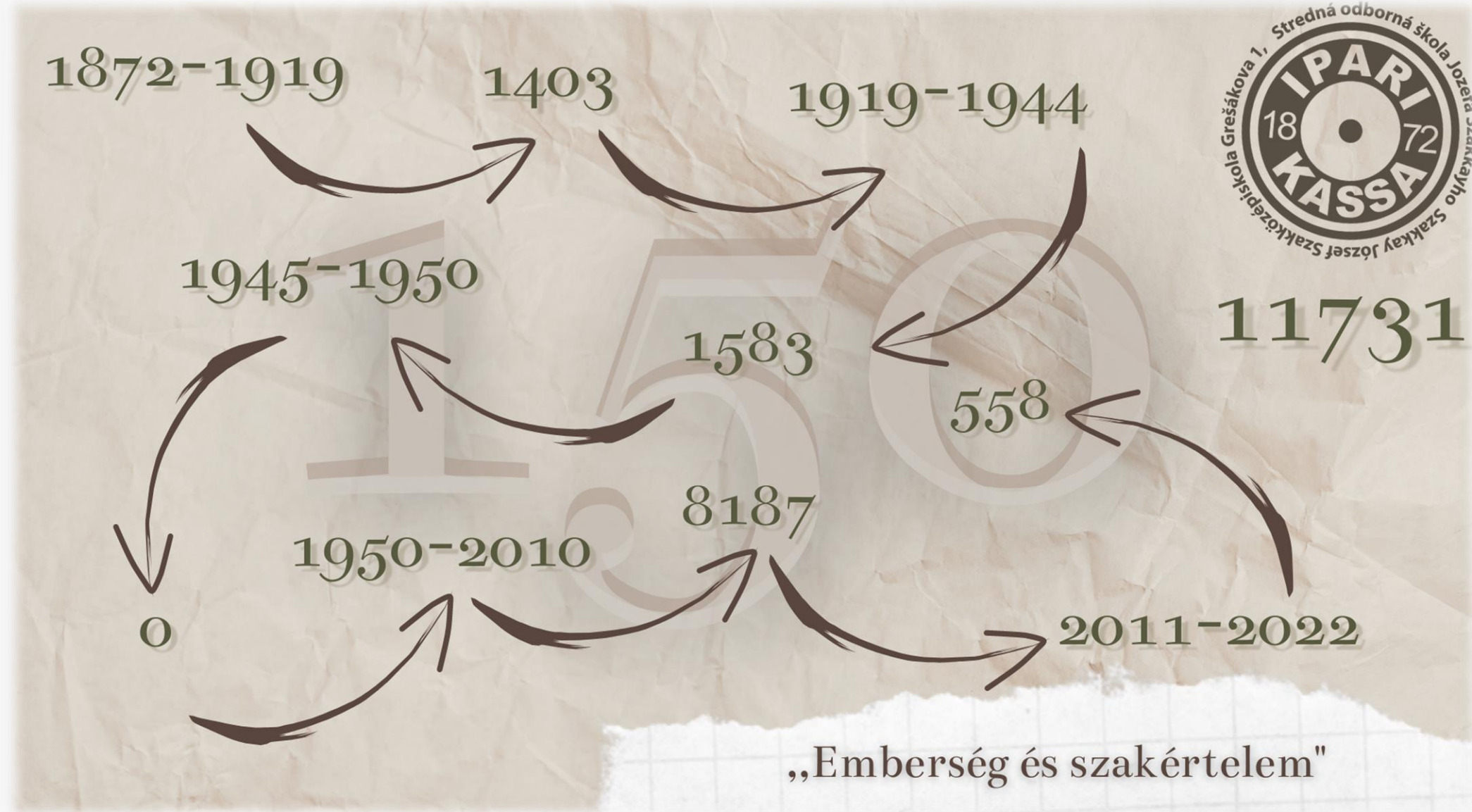

1993 felsőfokú szakképzés



1994 kereskedelmi akadémia



2010 műszaki líceum

műszaki líceum és kereskedelmi akadémia

*ŠOŠ J. Szakkayho - Szakkay József Szakközépiskola,
Grešákova 1, Košice 2010*



Staff:

- Kulesár Klaudia
- PhDr. Štefanco Judit
- Alberti Éva
- Ing. Pazder Erzsébet
- Ing. Matej Éva
- Ing. Caban Mária
- Mgr. Nagyné Fülöp Dóra
- Harča Zoltán
- Kusza Ádám
- Nagy Zoltán
- Kisfaludi András
- Barkai Ákos
- Bernáth Ádám

Students:

- Kőrösi Anita
- Buzogány Olivía
- Habodász Dominika
- Pilajdičko Nikolett
- Cseh Andrea
- Kun Fanni
- Nagy Tünde
- Papp Sándor
- Csicseri Bettina
- Pitöcký Evelin
- Hajdu Norbert
- Jankovič Dávid
- Korcsmáros Bence
- Tóbbias Sándor
- Hajdu Erik
- Príbeš Gergő

2010 - 2014

Ad Revidendum 2019



AZ ÉPÜLET

1872-től



akkor és most...



Tornaterem



Kollégium

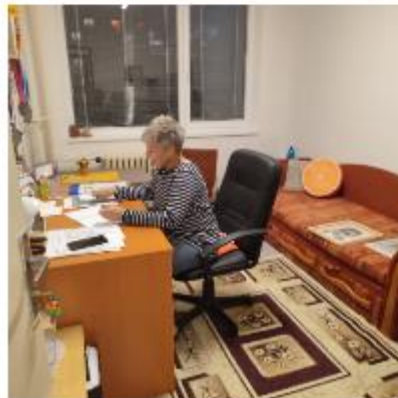

Megújuló tantermek





150



„ ...haladás nélkül nincs helyes út. “

Szakkay József

Az írásvetítőtől a „tapigép”-ig



Az osztálykönyvtől az Edupage-ig

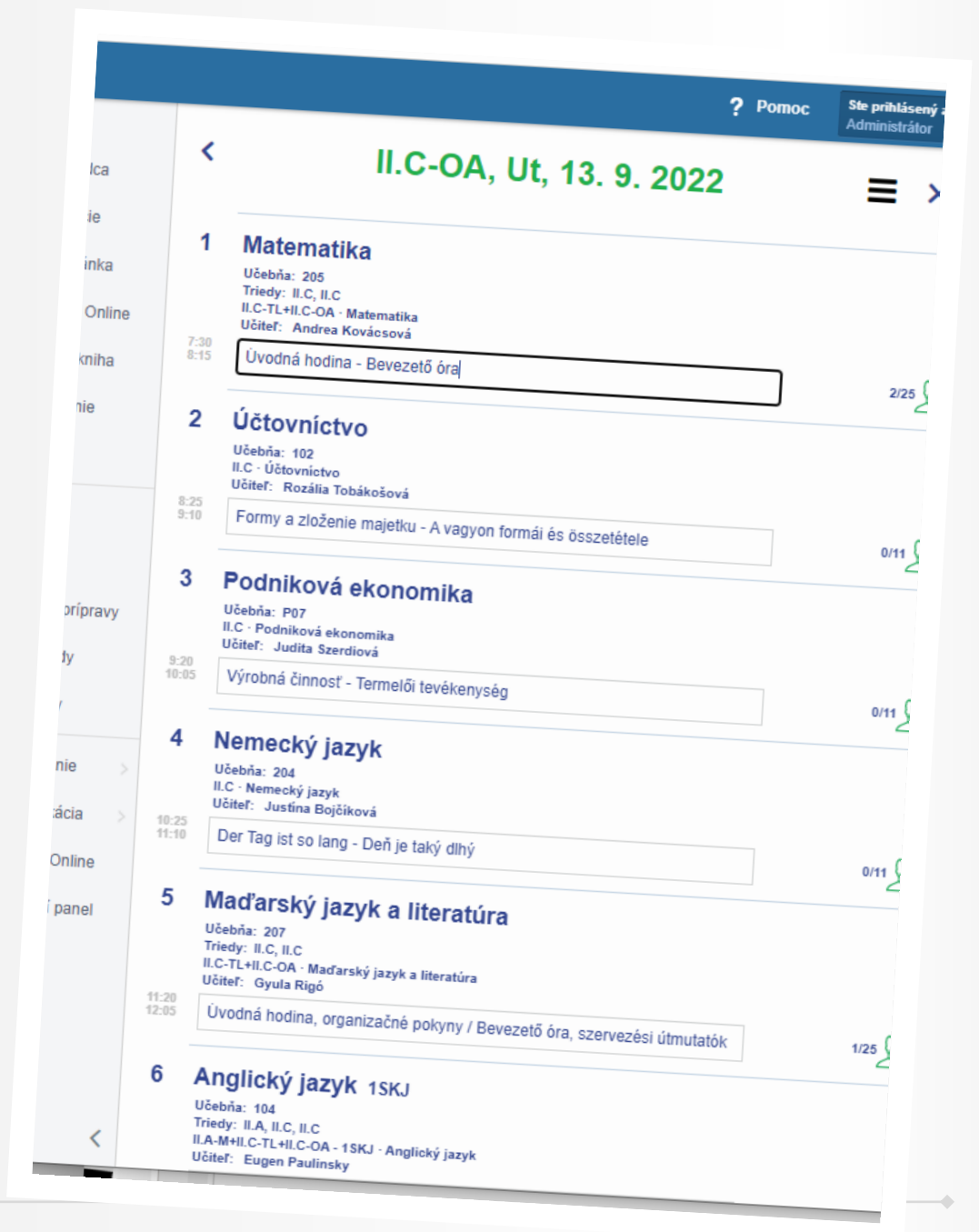
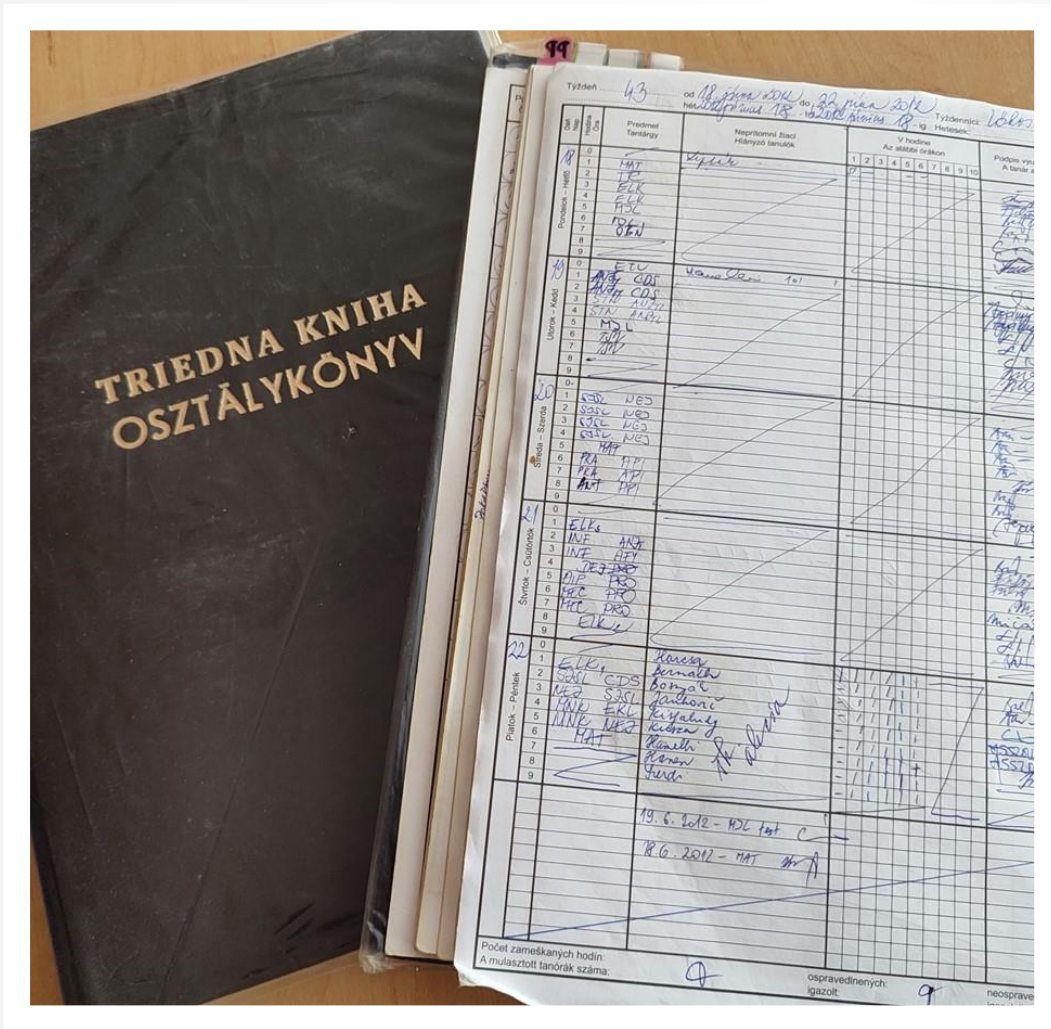

A jelenléttől a Teams-ig



A paus-papírtól a számítógépes modellezésig

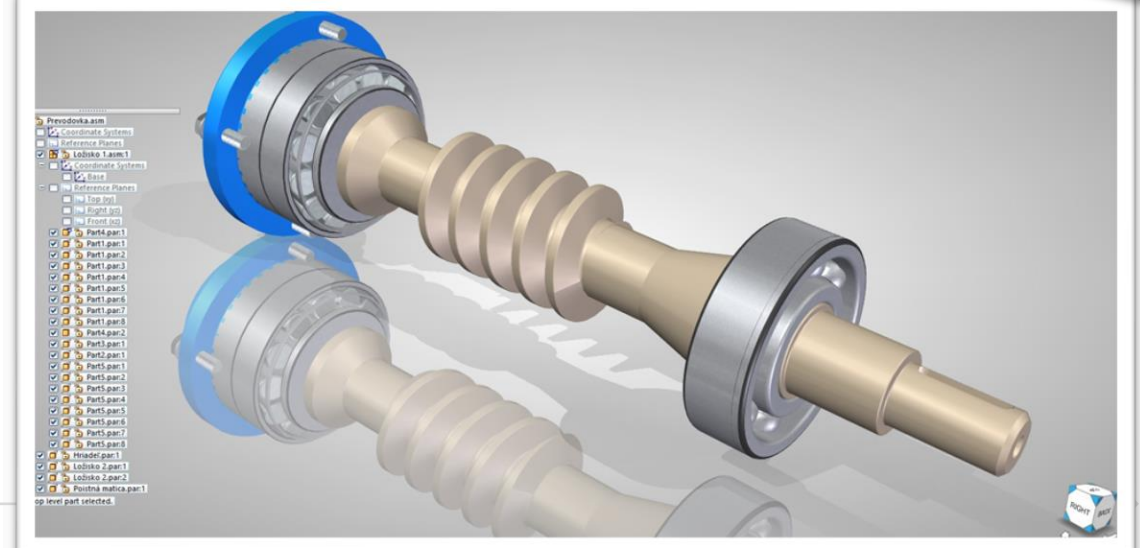
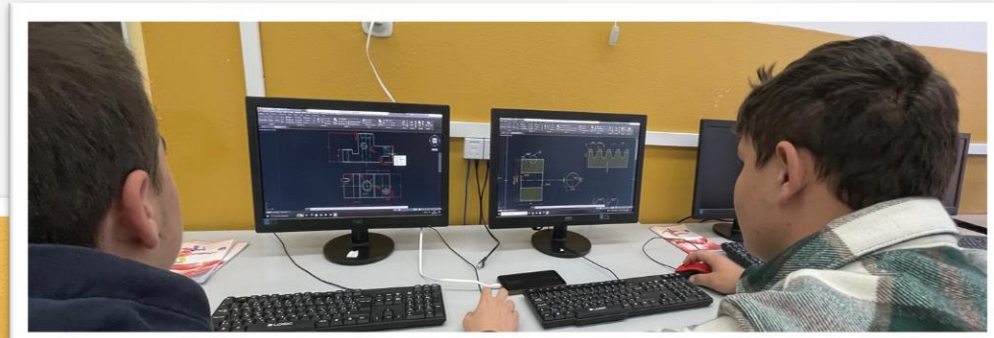
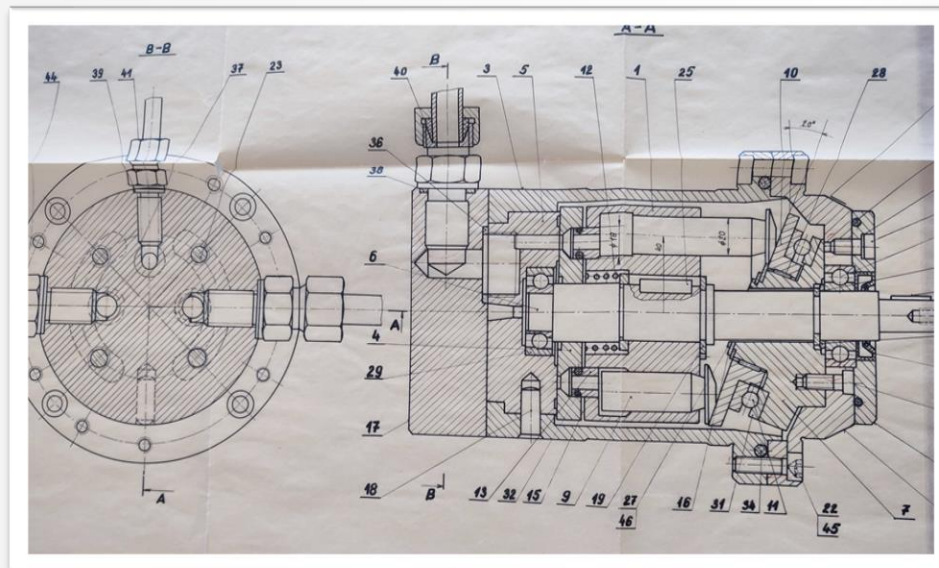

A tolómércétől a 3D mérőműszerig

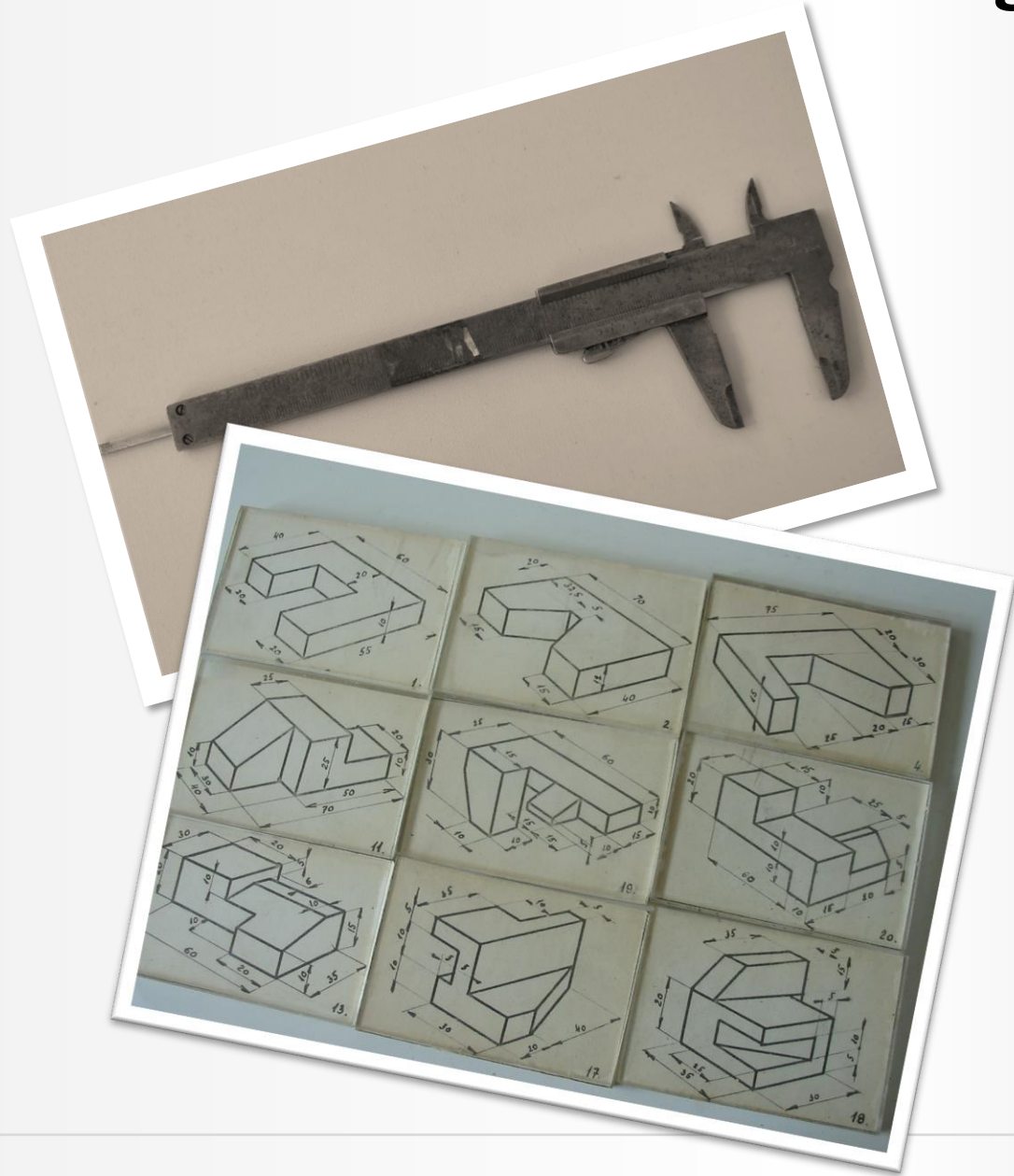

Az esztergapedtől a CNC-ig



A kézi gravírozástól a lézervágóig



Az automatizálás elméletétől a robotkarig

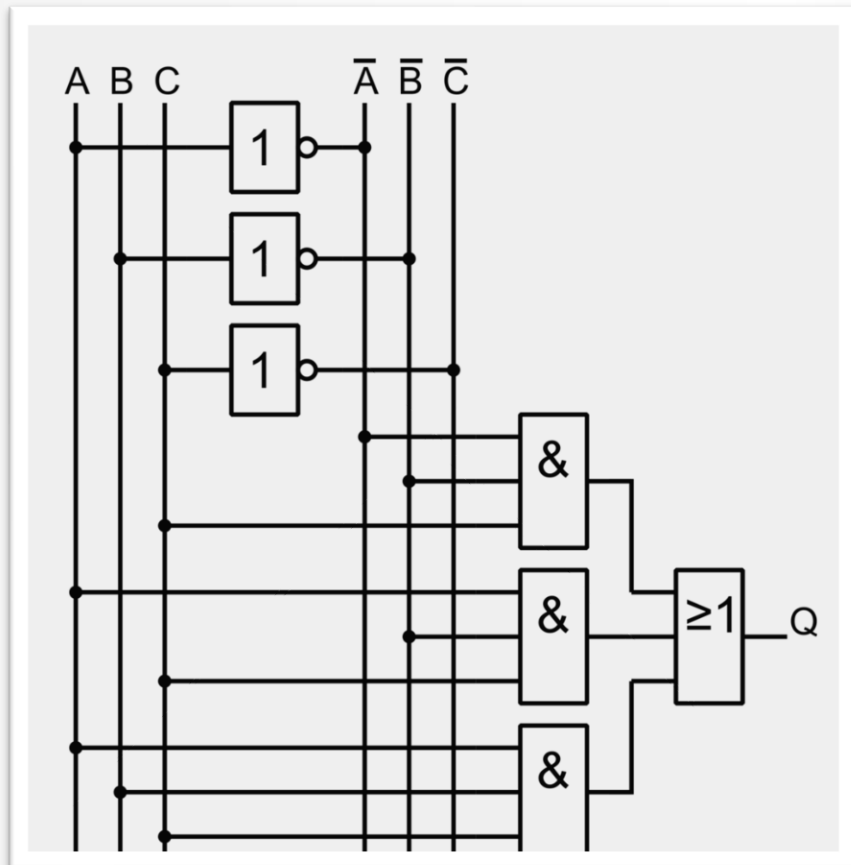

Bekötéstől a működésig

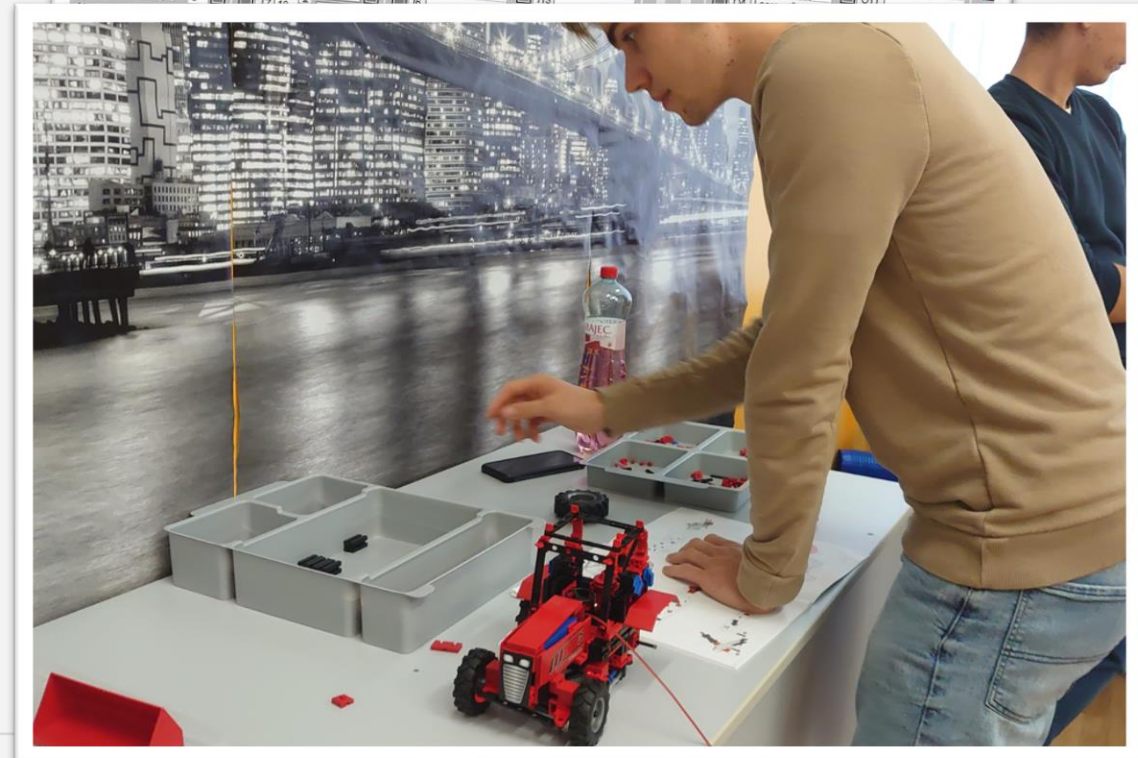
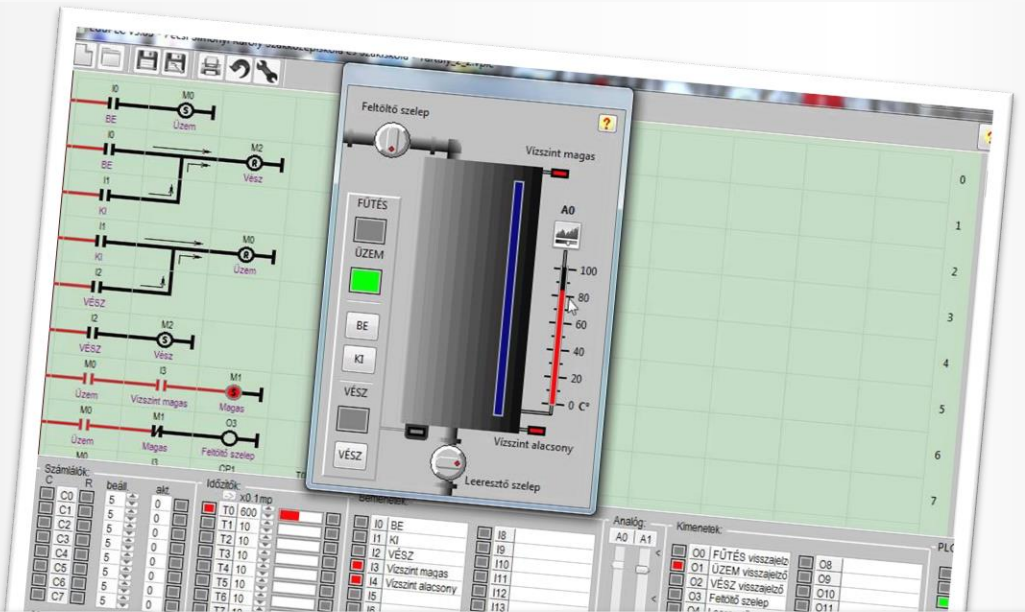
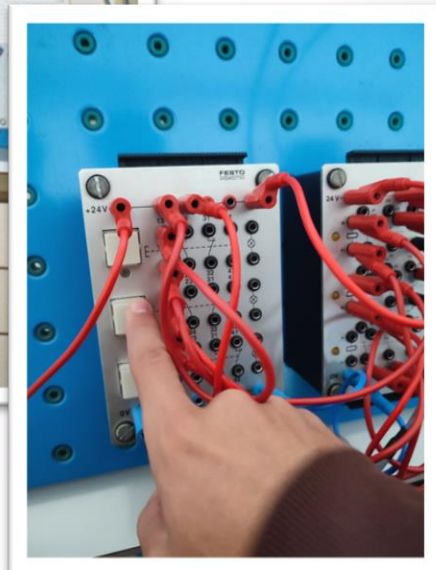

A számítástól a megvalósításig

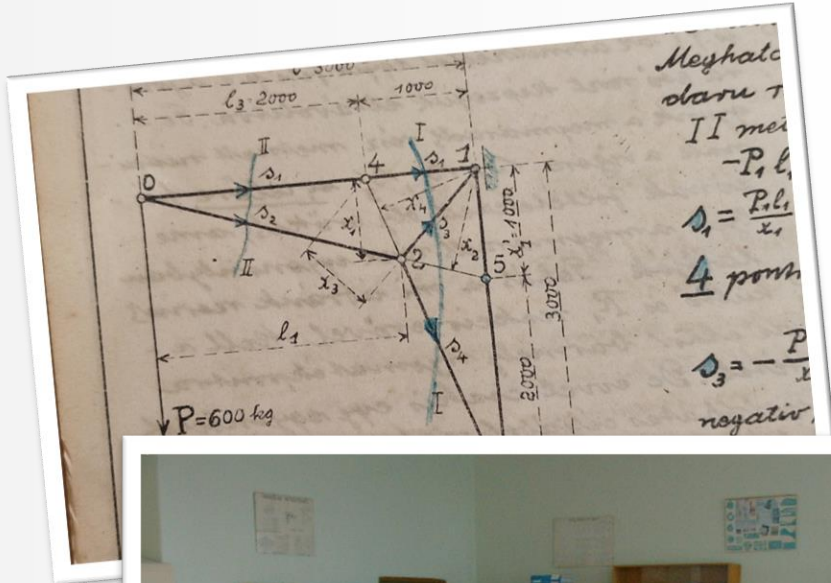

Elektrolabortól elektrolaborig

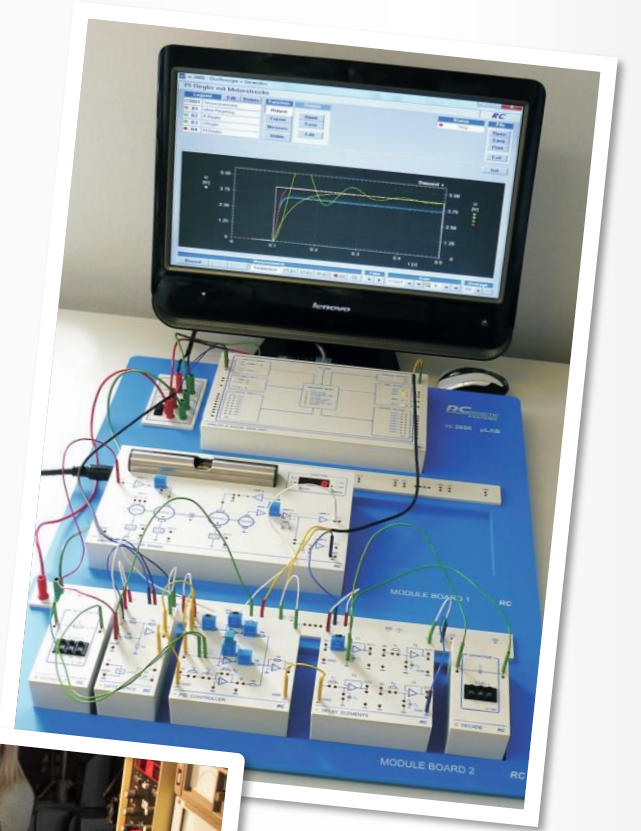

Mérőműszertől mérőműszerig



A degetől a mikrobitig

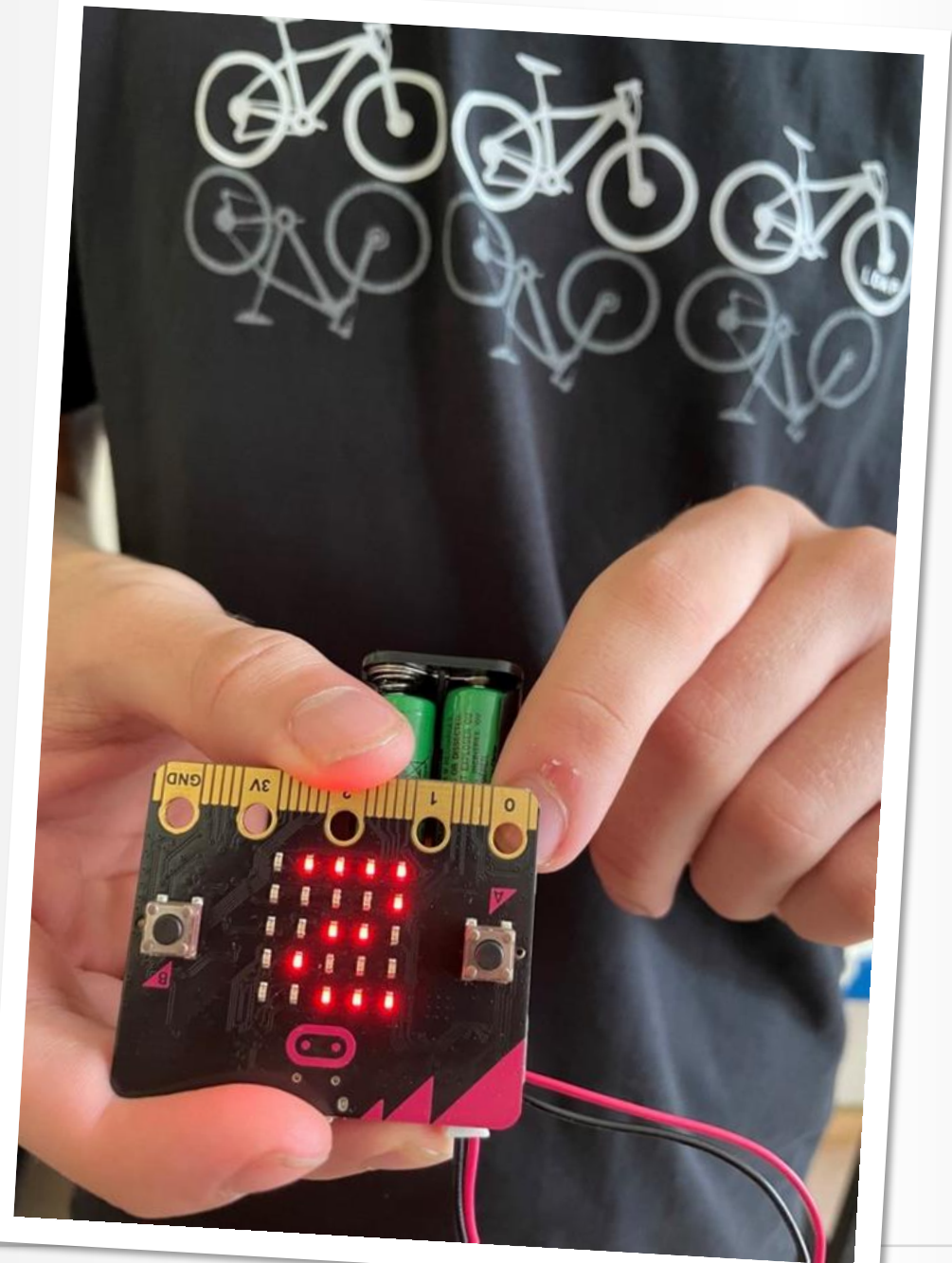

Az IBM writer-től a 3D nyomtatóig



Az írógéptől a tanirodáig

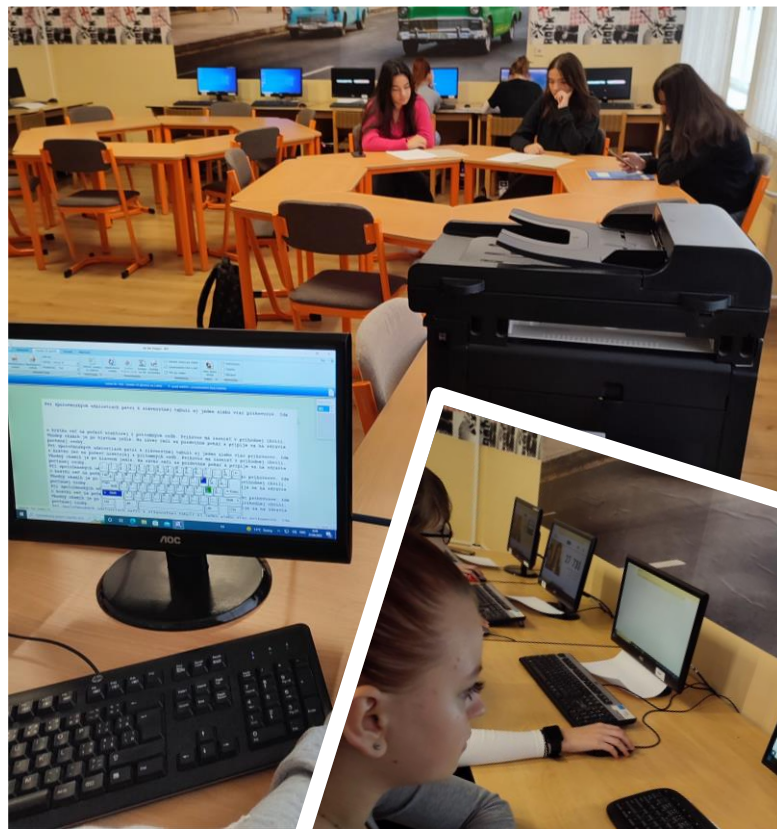

Elmélettől a gyakorlócégig

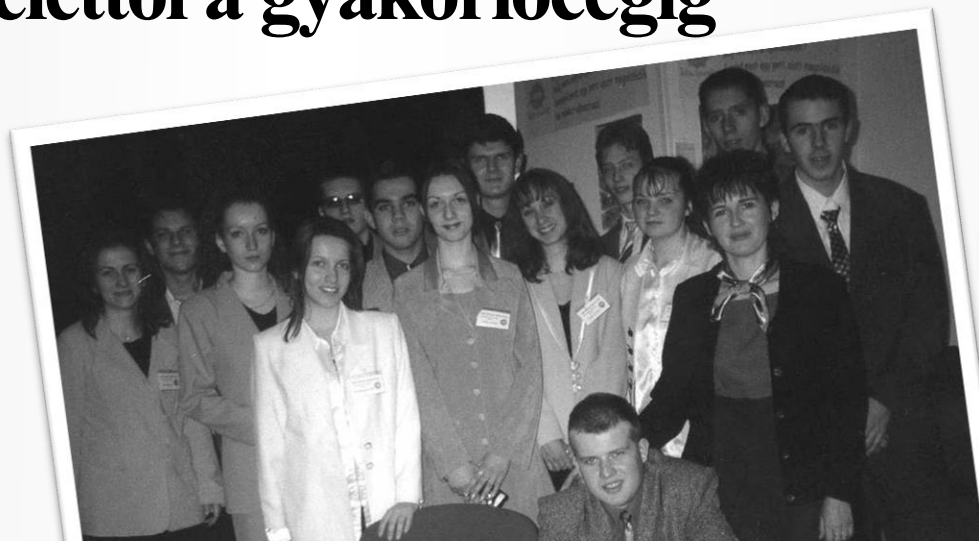

T betútól az Omegáig

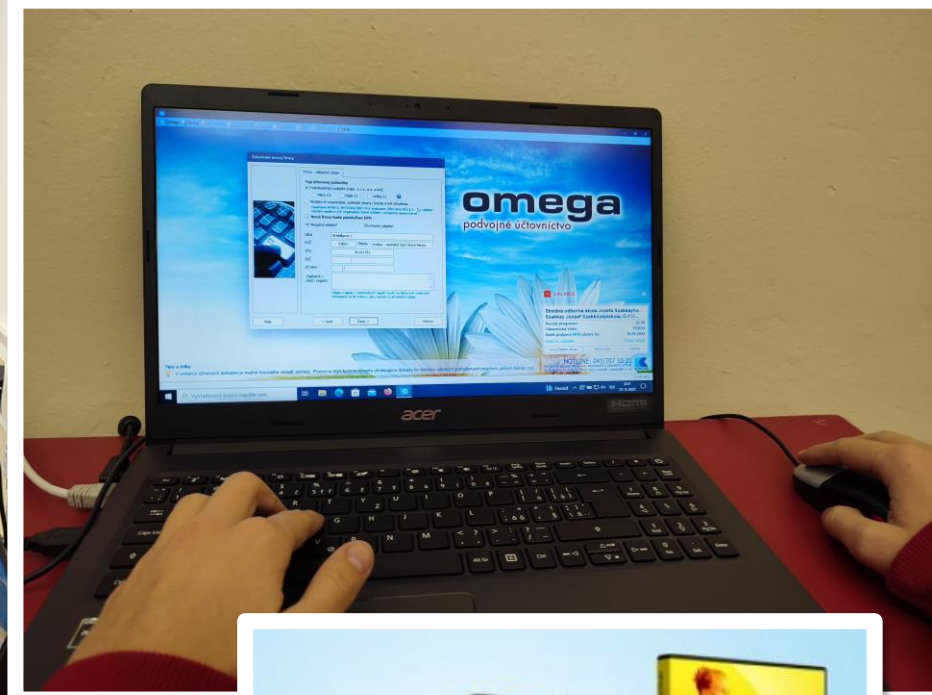
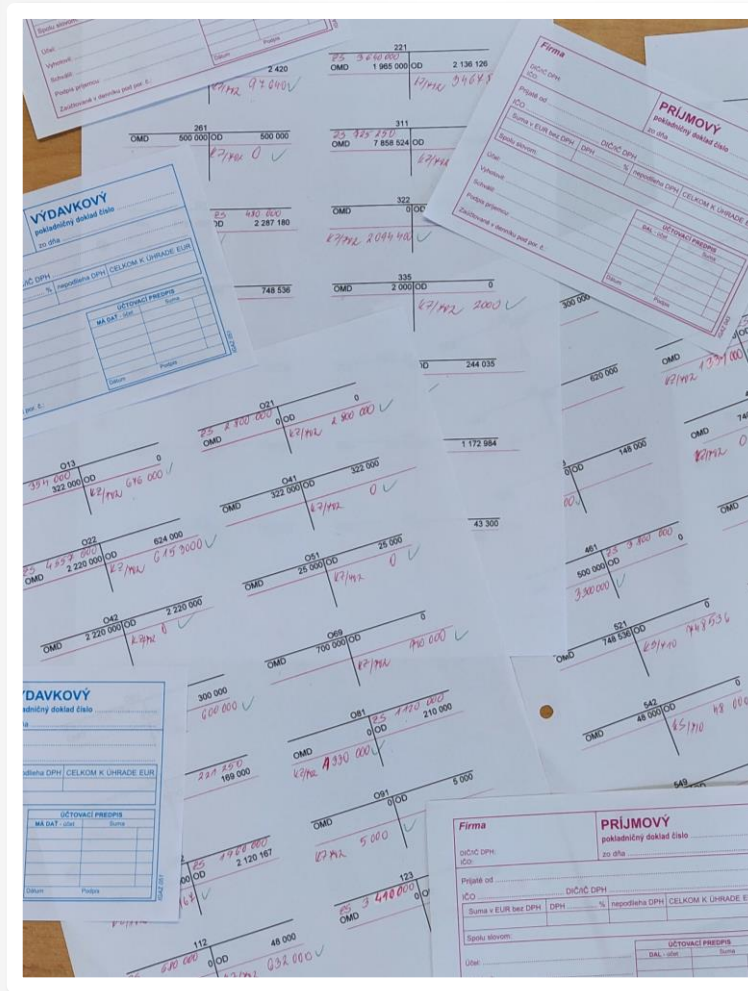

A kézzel szerkesztett diákújságtól a digitális változatig...



Van, ami alig változik...

```
3.141592653589793238462643383279
5028841971693993751058209749445923
07816406286208998628034825342117067
9821      48086      5132
823      06647      09384
46      09550      58223
17      25359      4081
          2848      1117
          4502      8410
          2701      9385
          21105     55964
          46229     48954
          9303      81964
          4288      10975
          66593     34461
          284756    48233
          78678     31652      71
          2019091   456485     66
          9234603   48610454326648
2133936   0726024914127
3724587   00660631558
817488    152092096
```

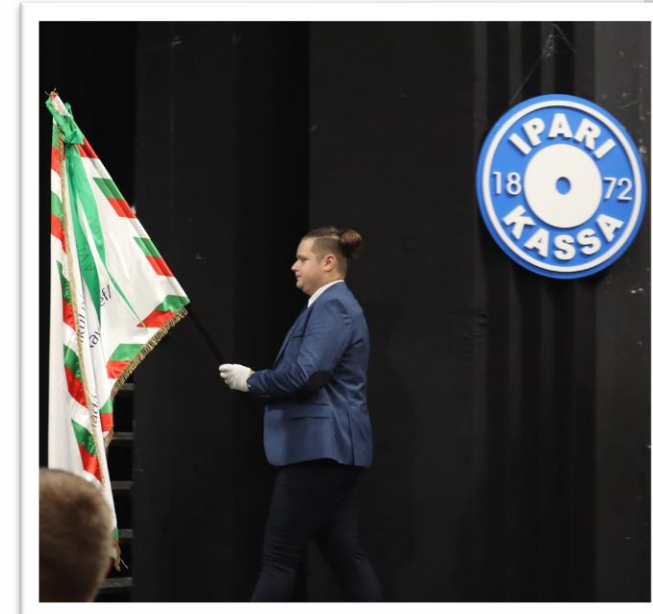
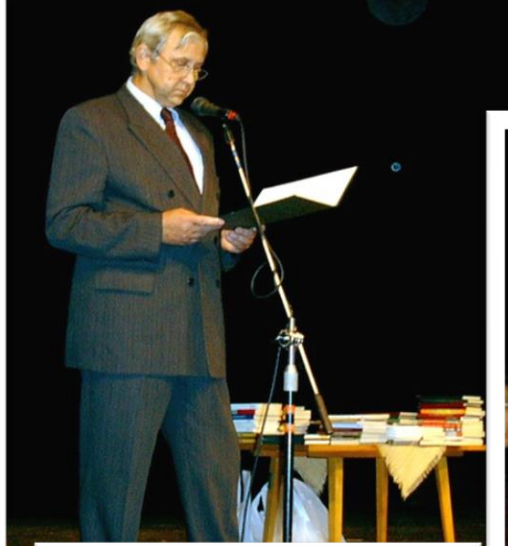

Tanévnyitó, tanévzáró



Ballagás

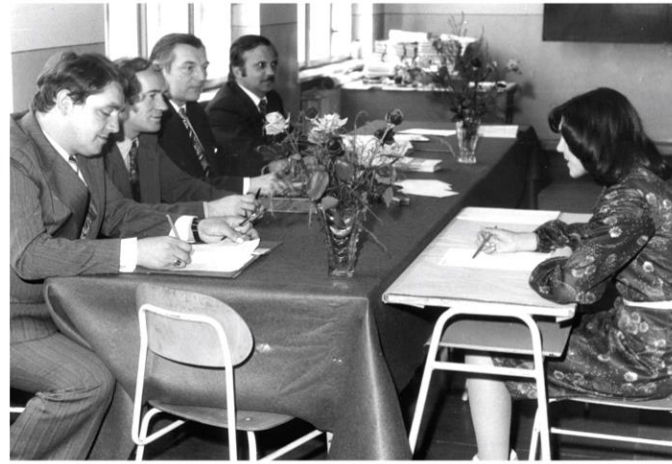

Érettségi vizsgák



Szakkay sír ápolása



Sítanfolyam



Sajnos már a múlté...



X

Iparista
Kis
Színpad



I Z I P A R I S T A
K S K I S
K S S Z Í N P A D
I Z

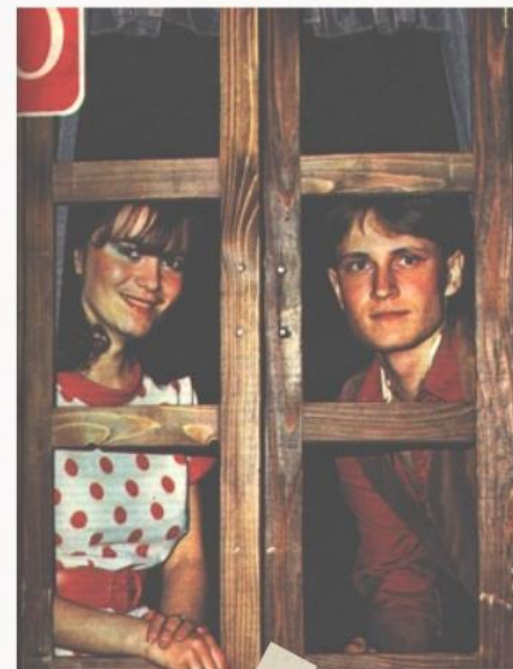

Iskolai zenekar



Május elsejei felvonulások

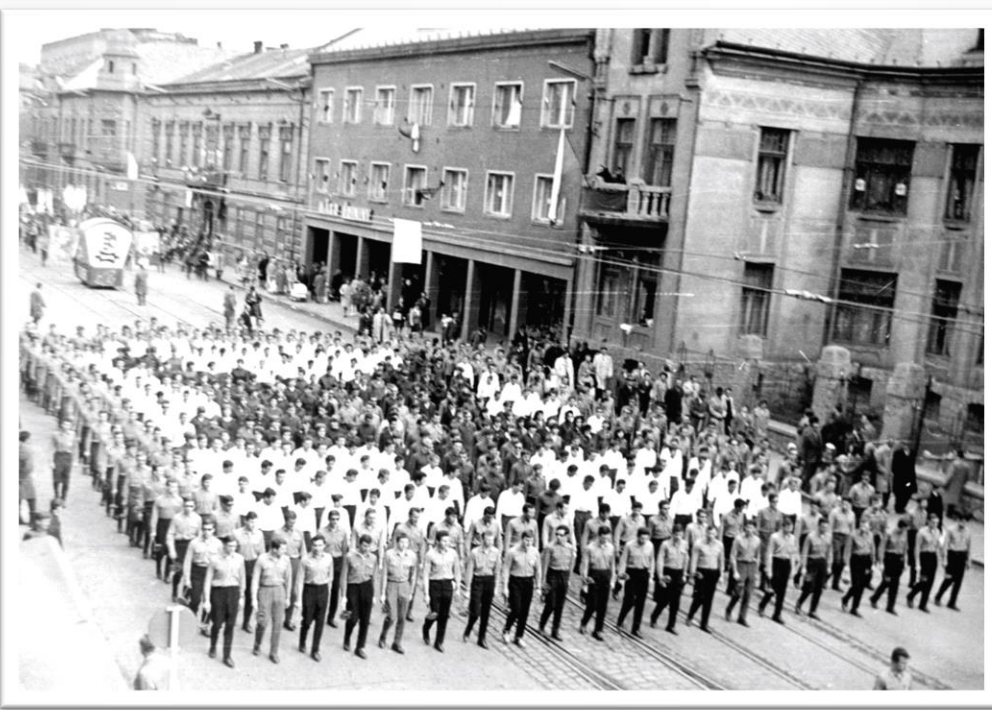

4.A 1968. május 1.

...milyen jó, hogy van!



Könyvtár



Robotika

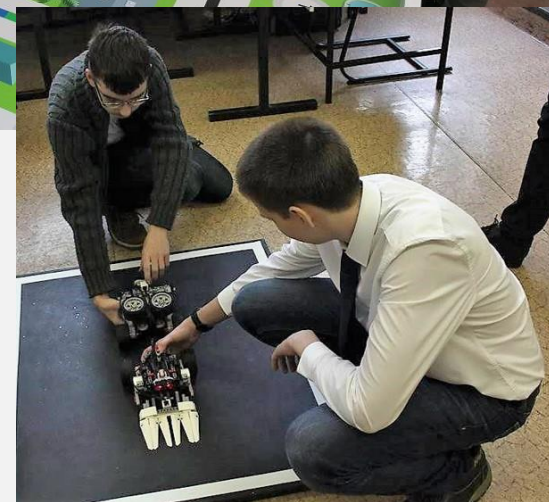

Tanulmányi kirándulások



Iskolai rendezvények



Erasmus V – 2022 június

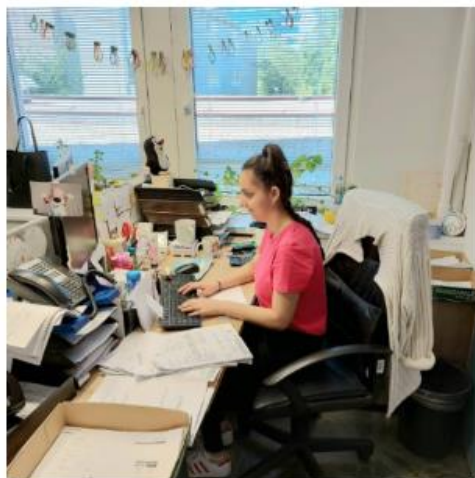

PRAHA(CZ)



MILANO(I)

Anyaországi kötődéseink

RÁKÓCZI
SZÖVETSÉG

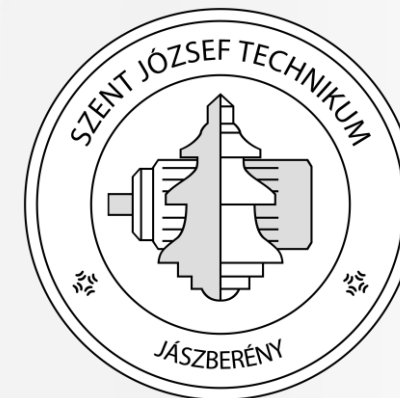
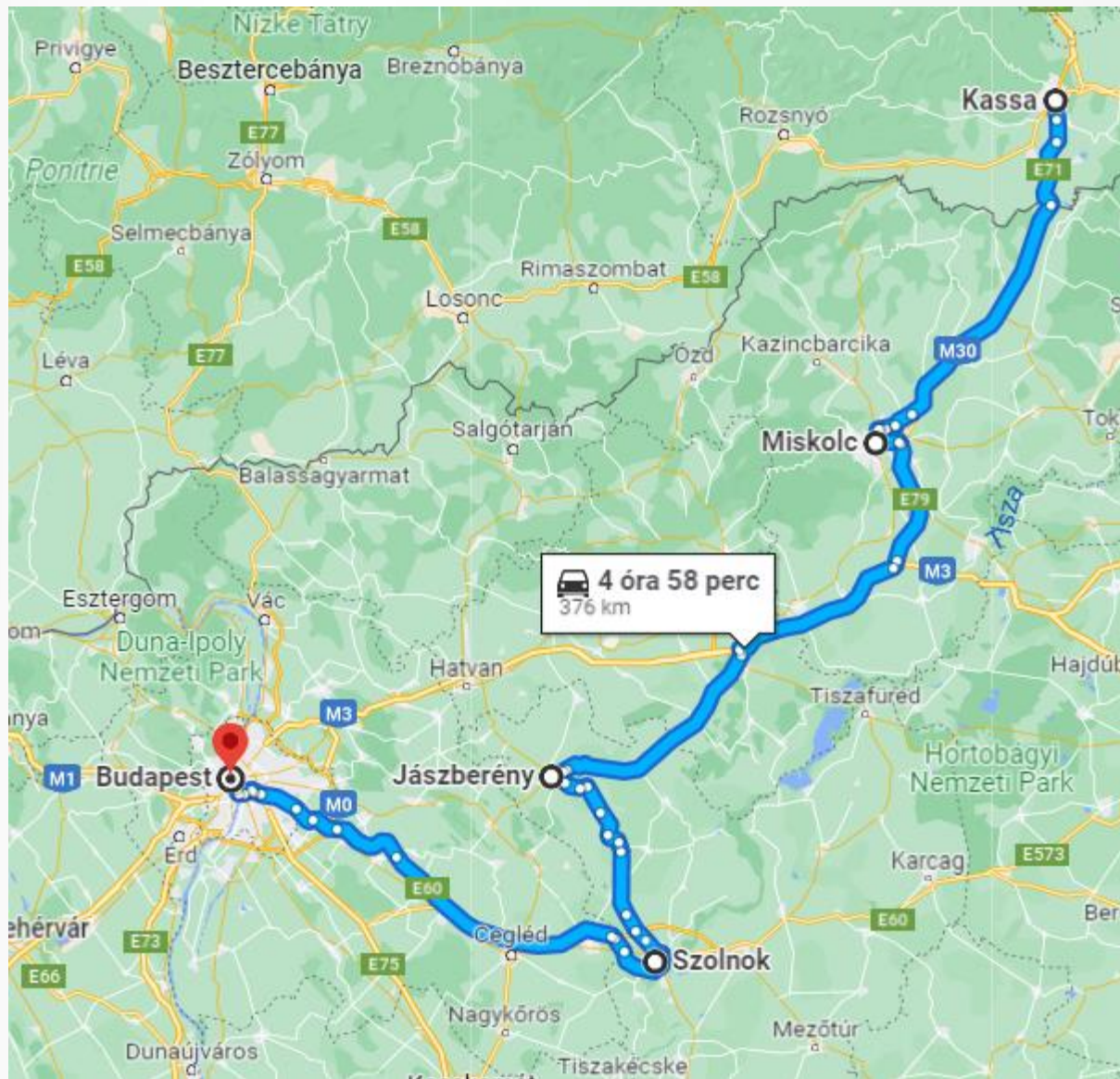

Tartjuk a kapcsolatokat...



...és újakat építünk



Iparista klubok

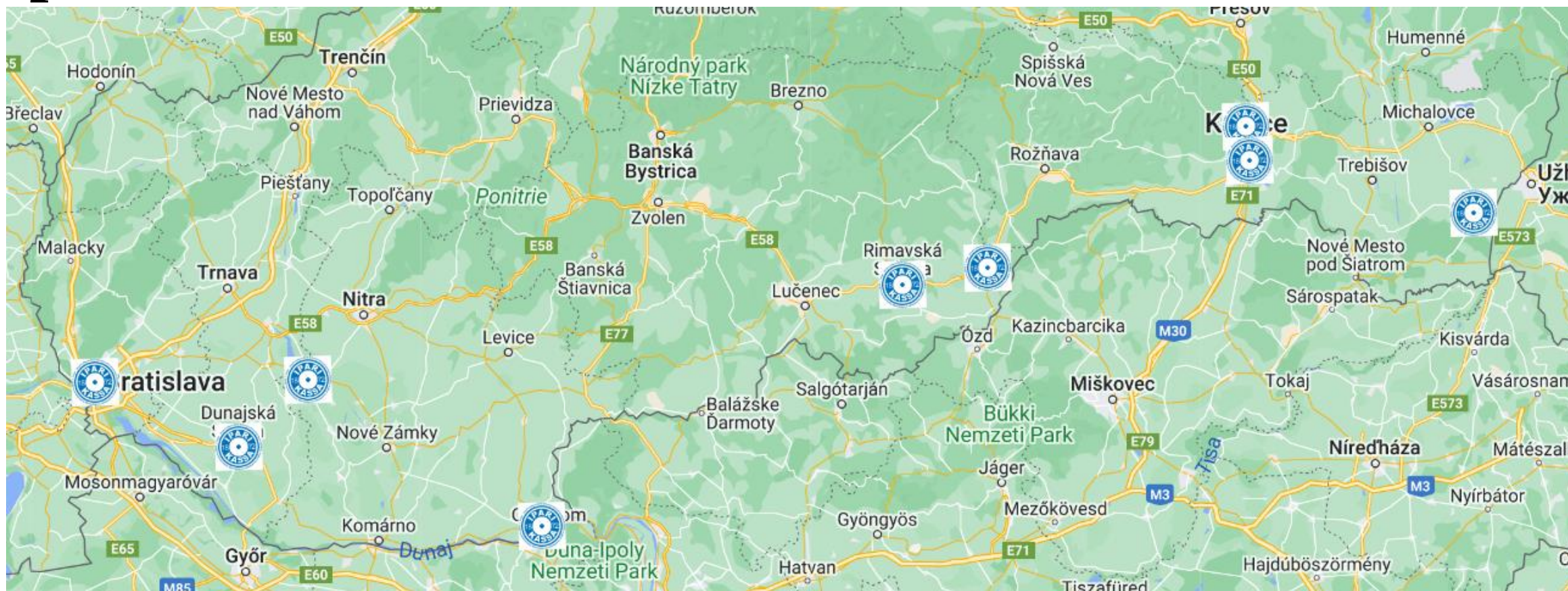

POZSONY

DUNASZERDAHELY

VÁGSELLYE

PÁRKÁNY

RIMASZOMBAT

TORNALJA

KASSA

KASSA (KIK)

NAGYKAPOS (UNGI)

Mit jelent iparistának lenni?

1971



Sliva Gábor, 1971 gépészet

- büszkeség,
- anyanyelvi oktatás,
- nemcsak tanulás – sport, szórakozás,
- szigorúság, követelmények,
- felvonulások – katonás rend,
- tisztelet.

1985



Mičák Zsuzsanna, 1985 gépészet

- családi hagyomány,
- összetartozás,
- egymás segítése,
- találkozó minden éven,
- az iskola támogatása.

2022



2022

- összetartozás,
- egymás megértése és elfogadása,
- haladunk a korrall,
- kreativitás,
- Iparista hagyományok.

Köszönjük! Éljen
“ az Iparista ”
nagy család!

Külön köszönet a FORRÁSokért:

Ing. Pulen Lajos egykori igazgatóknak, akinek a könyveiből az információkat feldolgoztuk.

Ing. Pál Tibor egykori tanárunknak, aki nagymennyiségű elektronikus fotodokumentációt hagyott ránk.



Továbbá köszönjük Kővágó Tamás
(1970, energetika)
és Pekárovics Anett
(1998, kereskedelmi akadémia)
értékes személyes fotóit.